

# ARGON

## TRANSFORM



# PRODUCT MANUAL

WHYRE © 2020

## **PARTS INCLUDED**

- 1 x Front HUD
- 1 x Rear camera module
- 1 x Rear helmet mount
- 1 x Controller device
- 1 x USB C to C (right angle) cable
- 1 x Micro USB cable
- 1 x Audio cable
- 1 x Controller strap

## **CONTENTS**

- 1 Initial Setup & Installation
- 2 Controller Device Buttons
- 3 HUD Display Modes
- 4 Troubleshooting & Precautions

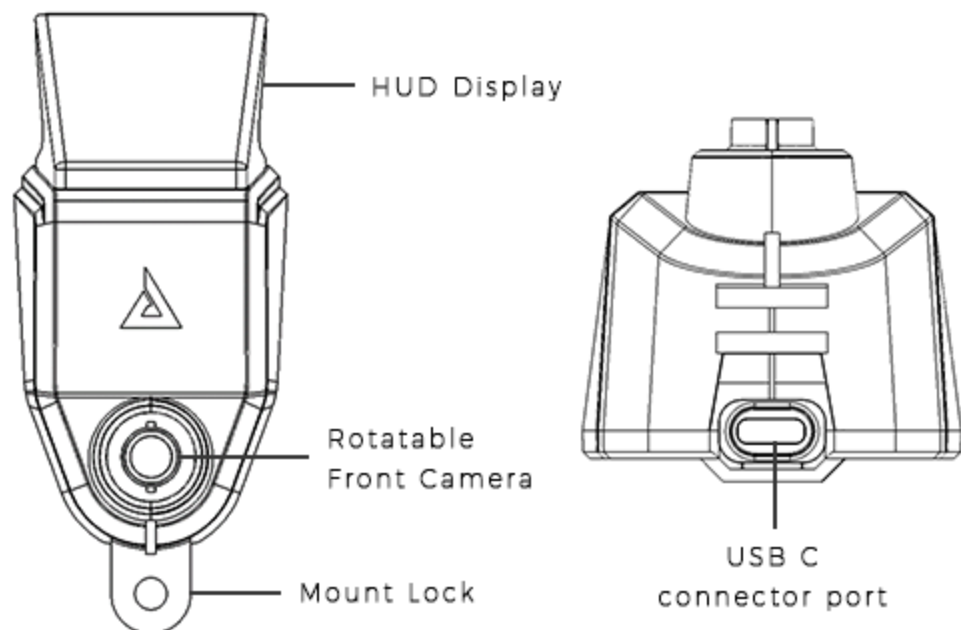

1. For initial setup, connect the right angled USB C to C cable head provided to the front attachment connector port (according to image above).

2. Secure Front attachment to mounting accessories via the mount lock. Experimenting for optimal viewing position while wearing your helmet is strongly advised before applying the 3m adhesive to the helmet.

3. Adjust rotatable front camera towards your preferred viewing position only after installing on the helmet.

**Note:** All connectors must be connected firmly to prevent water damage to device.

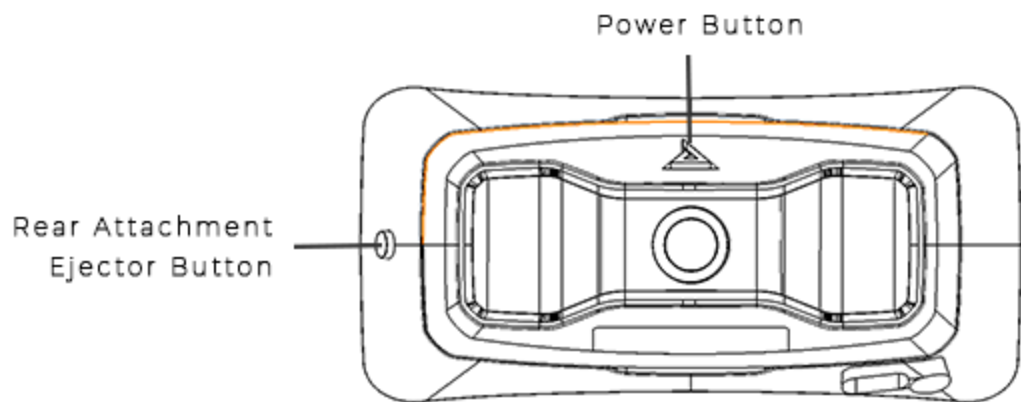
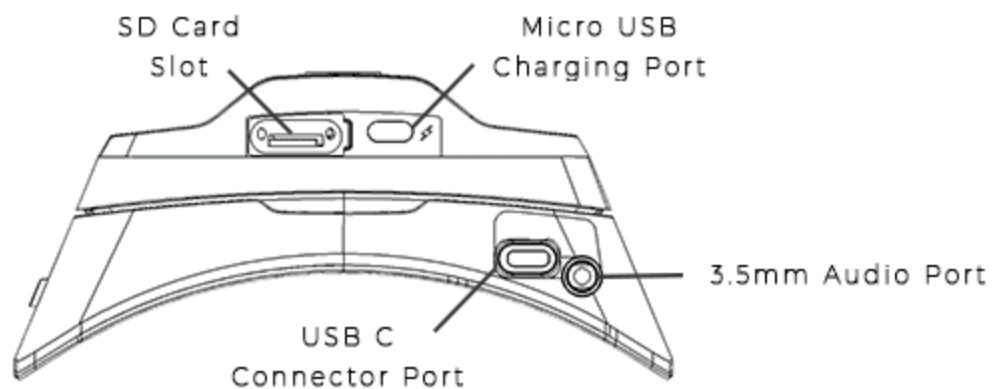

2. Connect the other end of the USB C to C cable head to the USB C connector port on the rear mount. Insert 3.5mm audio jack into audio port for sound.

3. Ensure that rear camera module is firmly combined to the rear helmet mount before turning on device.

4. Hold briefly on the power button and check that the HUD display has lit up with the home screen.

**Note:** Tightly fit all connector ports with the respective cables and also ensure SD card slot flap is sealed before using device.

*\*Dual recording only available in simplified navigation mode*

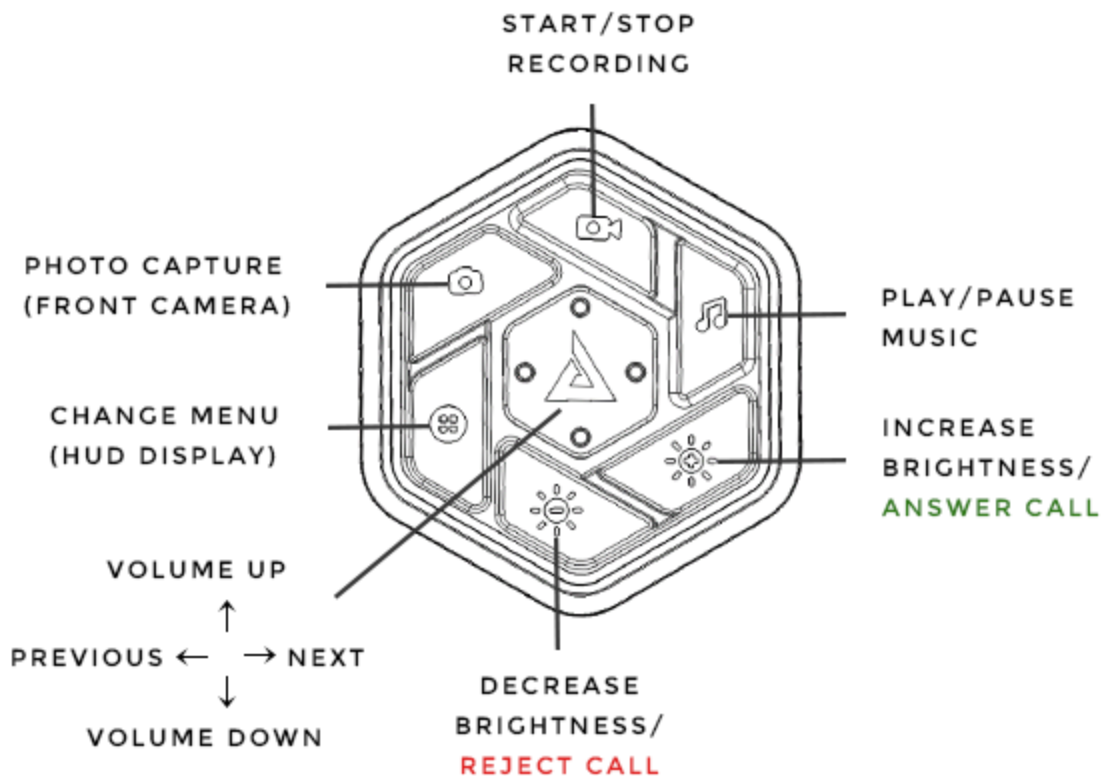

1. To connect controller to device, press any button during back piece booting (10 second window).

2. If connecting controller independently, use the Argon mobile app to refresh the controller connection and select appropriate controller to connect.

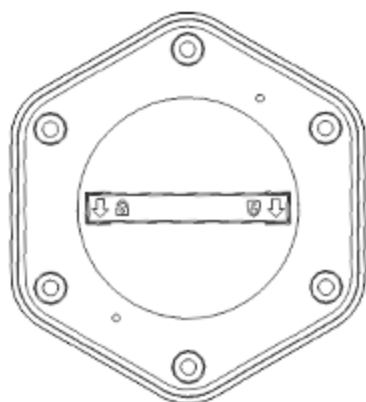

1. Twist open battery cap and insert button cell for initial set up. (+ side facing out)

*\*Ensure cap is closed tight*

## REAR VIEW MODE ICONS



CONTROLLER NOT CONNECTED



FRONT DASHCAM NOT CONNECTED  
(\*RECONNECT USB C CABLE)



VIDEO RECORDING ON



MUSIC PLAYING/MUSIC MODE ON

## SIMPLIFIED GPS MODE

DUAL RECORDING ONLY  
AVAILABLE IN THIS MODE

\*NOTE: SIMPLIFIED GPS  
MODE DOES NOT DISPLAY  
REAR VIEW OR FRONT  
CAMERA FEED.



## **TROUBLESHOOTING & PRECAUTIONS**

### **FRONT HUD FLICKERING & AUDIO INTERMITTENT**

Ensure that the USB C and audio jacks have been refitted tightly to prevent choppy connection. Connecting ports are deliberately made tight-fit to prevent water from entering when used outdoors.

*(Note: Initial insertion of new connectors might be tighter than usual)*

### **CONTROLLER NOT CONNECTED**

On device startup, a 10 second window is available to connect the controller to the device by pushing any button on the controller.

If window period is missed, Use the Argon Transform mobile app to reconnect the button to the device.

1. Open Argon Transform Mobile App
2. Click "Quick connect Argon"
3. Click and connect Rear device (Bluetooth) to mobile device
4. Access "Quick connect Argon" (more icons now available)
5. Click on Button Controller icon (push any button on the controller to wake controller from sleep mode.

### **GPS & SPEEDOMETER NOT FUNCTIONING**

Ensure that device is connected to Argon mobile app with mobile device's Bluetooth and Location turned on.

*(Note: Only in-app GPS navigation is compatible with device. 3rd party navigations will only be audio navigations through speaker set.)*

## **TROUBLESHOOTING & PRECAUTIONS**

### ***SOFT RESET INSTRUCTIONS***

Hold the power button for 15 seconds. Note, device will shut down and power up again.

### ***HARD RESET INSTRUCTIONS***

1. Turn On the device by itself without attaching to the rear mount (indicated by flashing lights below)
2. Use a conducting screw driver or test pen to touch 2 specific pins indicated in the image below. (the 2 pins on the third row from the top)
3. The device should **turn off permanently** (unable to turn on using the power button)
4. To wake the device, plug in the powered micro-USB charging cable to the device (red light should appear when plugged in)
5. Turn on device and connect normally





## **BLUETOOTH PAIRING INSTRUCTIONS**

### ***ANDROID USERS***

1. ENSURE DEVICE IS FIRST PAIRED WITH YOUR MOBILE PHONE'S BLUETOOTH IN YOUR MOBILE SYSTEM SETTINGS
2. ENTER MOBILE APP TO ENSURE THAT DEVICE HAS BEEN CONNECTED IN QUICK CONNECT MENU (IN MOBILE APP)